

# **GR**Reddy®

## ***GR*Reddy Turbo Kit**

Toyota Supra TT JZA80 (2JZ-GTE)

T-78 / T-88



## Toyota Supra TT JZA80 ( 2JZ-GTE )

# Installation Manual

Please read the entire manual before installing this kit.

### Application:

Make	Model	Chassis	Year
Toyota	Supra	JZA80	93-97

- This **GRReddy T-78/T-88 Turbo Kit** is designed only for the vehicles specified above, although it is specifically designed for Japanese spec. Supra. Therefor you must also purchase **GRacer Airinx Adapter for '93-97 Supra #525901** to accommodate the air flow meter found on USA spec vehicles. The suction pipe requires so modification.
- This **GRReddy T-78/T-88 Turbo Kit** is a complete bolt on replacement and once installed it is ready for use. For optimum performance it is highly recommend to also install the **GRReddy JZA80 Blow-off Valve Kit**, and especially the **GRReddy Intercooler Kit** for JZA80.
- This **GRReddy T-78/T-88 Turbo Kit** is legal in California only for racing vehicles which may never be used upon a highway.

# JZA80 T-78/T-88 Turbo Kit

## 1. Parts List

1. Choice of (GReddy T-78 or T-88)	1
2. Type R external wastegate	1
3. 42Ø SUS turbo exhaust manifold	1
4. Wastegate dump pipe 50Ø (steel)	1
5. Turbo down pipe 80Ø (steel)	1
6. Charge pipe C-1 60Ø (aluminum) 120° 30R	1
7. Charge pipe C-2 60Ø (steel)	1
8. Turbo suction pipe 100Ø (aluminum)	1
9. Heat shield bracket	1
10. Air filter (Airinx AX-M)	1
11. Airinx adapter	1
12. Oil pressure hose SUS 600mm	1
13. Oil pressure banjo fitting set (male & female)	1
14. Adapter union 12mm P1.25-10mm P1.25	1
15. Straight union 1/8PF-10mm P1.25	1
16. Plug bolt 12mm P1.25	1
17. Copper washer 10Ø t=1.0 (turbo side)	2
18. Copper washer 10Ø t=2.0 (engine side)	1
19. Copper washer 12Ø (engine side)	2
20. Oil return flanged pipe 19Ø (turbo side)	1
21. Oil return flanged pipe 19Ø (engine side)	1
22. Silicone hose 60Ø x 70mm	1
23. Silicone hose 100Ø x 60mm	2
24. Silicone hose 60Ø - 65Ø (reducer)	1
25. Silicone hose 60Ø - 70Ø (reducer)	1
26. Rubber hose 6Ø x 500mm	1
27. Rubber hose 8Ø x 1100mm	1
28. Rubber hose 12Ø x 450mm	1
29. Rubber hose 19Ø x 1250mm (ISCV)	1
30. Hose band #4 6Ø	4
31. Hose band #8 12Ø	2
32. Hose band #12 19Ø	4
33. Hose band #36 60Ø	4
34. Hose band #40 65Ø	1
35. Hose band #44 70Ø	1
36. Hose band #64 100Ø	4
37. Air pressure hose 600mm	1
38. Air pressure hose 800mm	1

39.	Straight union fitting	1/8pt - 1/8of								2
40.	Hose union fitting	5Ø - 1/8pt								1
41.	Hose union fitting	6Ø - 1/8pt								1
42.	Exhaust manifold gasket									1
43.	Turbo gasket	(IN)								1
44.	Turbo gasket	(OUT)								1
45.	Exhaust gasket (Muffler)	80Ø								1
46.	Oil return gasket									2
47.	O <sup>2</sup> sensor gasket									1
48.	Plug union	10Ø								2
49.	Heat shield									1
50.	Thermo cloth	100mm x 1000mm								1
51.	Tie wrap	150mm								5
52.	M6 x 25mm	P=1.0	(Airinx)	B	S/W	-	-			4
53.	M6 x 15mm	P=1.0	(heat shield)	B	S/W	F/W				1
54.	M8 x 15mm	P=1.25	(heat shield)	B	S/W	F/W	N			1
55.	M8 x 25mm	P=1.25	(O2 sensor)	B	S/W	F/W	N			2
56.	M10 x 25mm	P=1.5	(oil return / down pipe)	B	S/W	-	N			6
57.	M10 x 35mm	P=1.25	(exhaust mani.)	B	S/W	-	N			16
58.	M10 x 35mm	P=1.25	(down pipe)	B	-	-	N			2

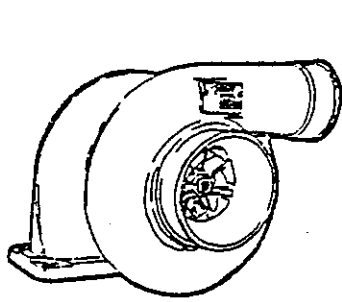

1

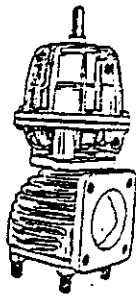

2

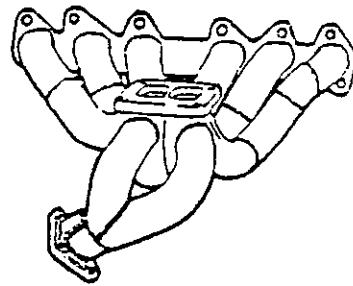

3

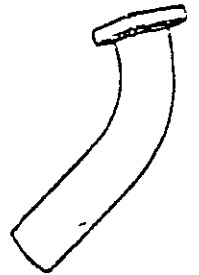

4

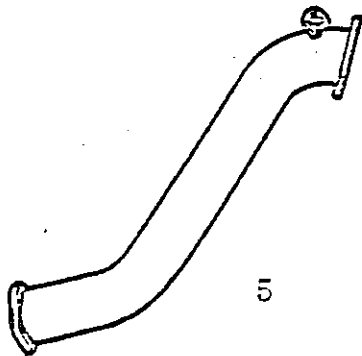

5



6

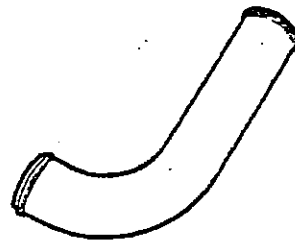

7

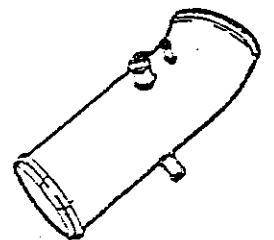

8



9

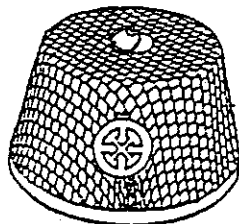

10



11

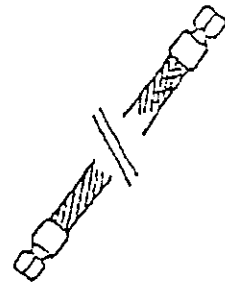

12

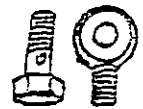

13



14



15



16



17



18



19

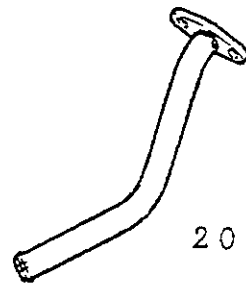

20



21



22



23



24



25

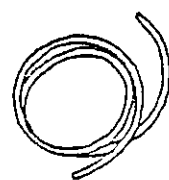

26

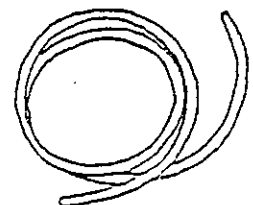

27

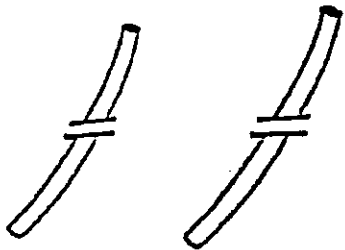

28

29



30



31



32



33



34

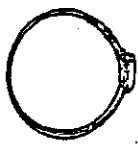

35

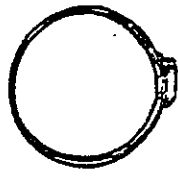

36

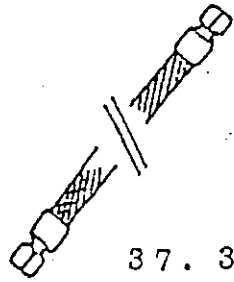

37. 38



39

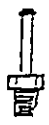

40

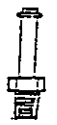

41

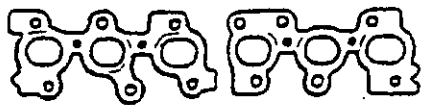

42

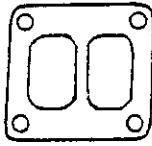

43

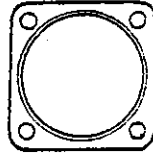

44

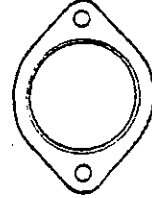

45



46



47



48

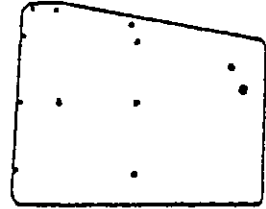

49



50



51



52



53

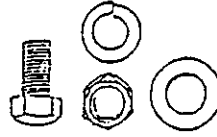

54

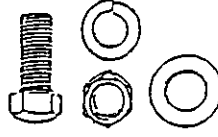

55

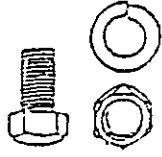

56

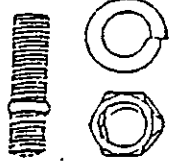

57

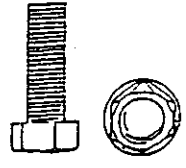

58

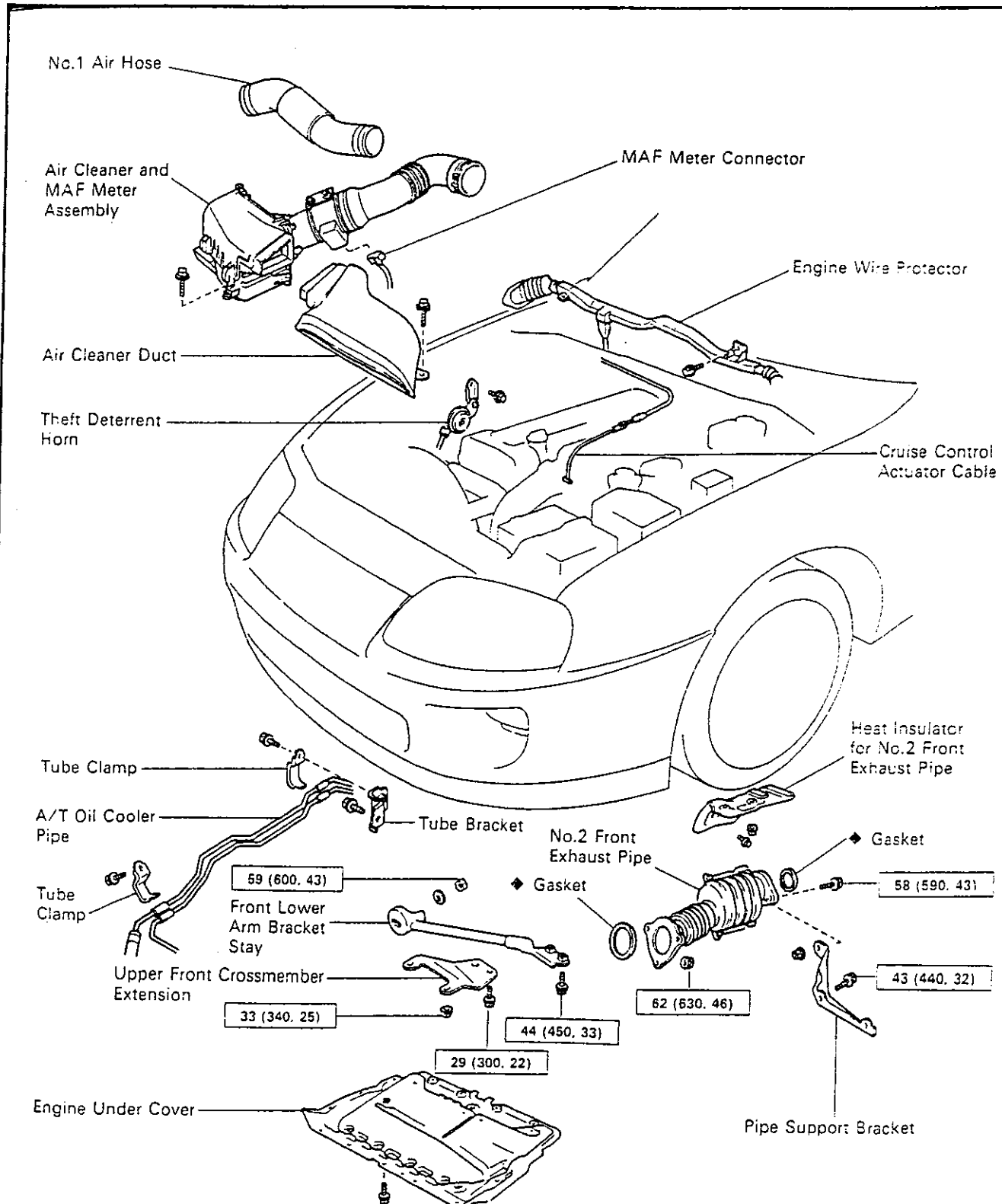

N·m (kgf·cm, ft·lbf) : Specified torque  
 ◆ Non-reusable part

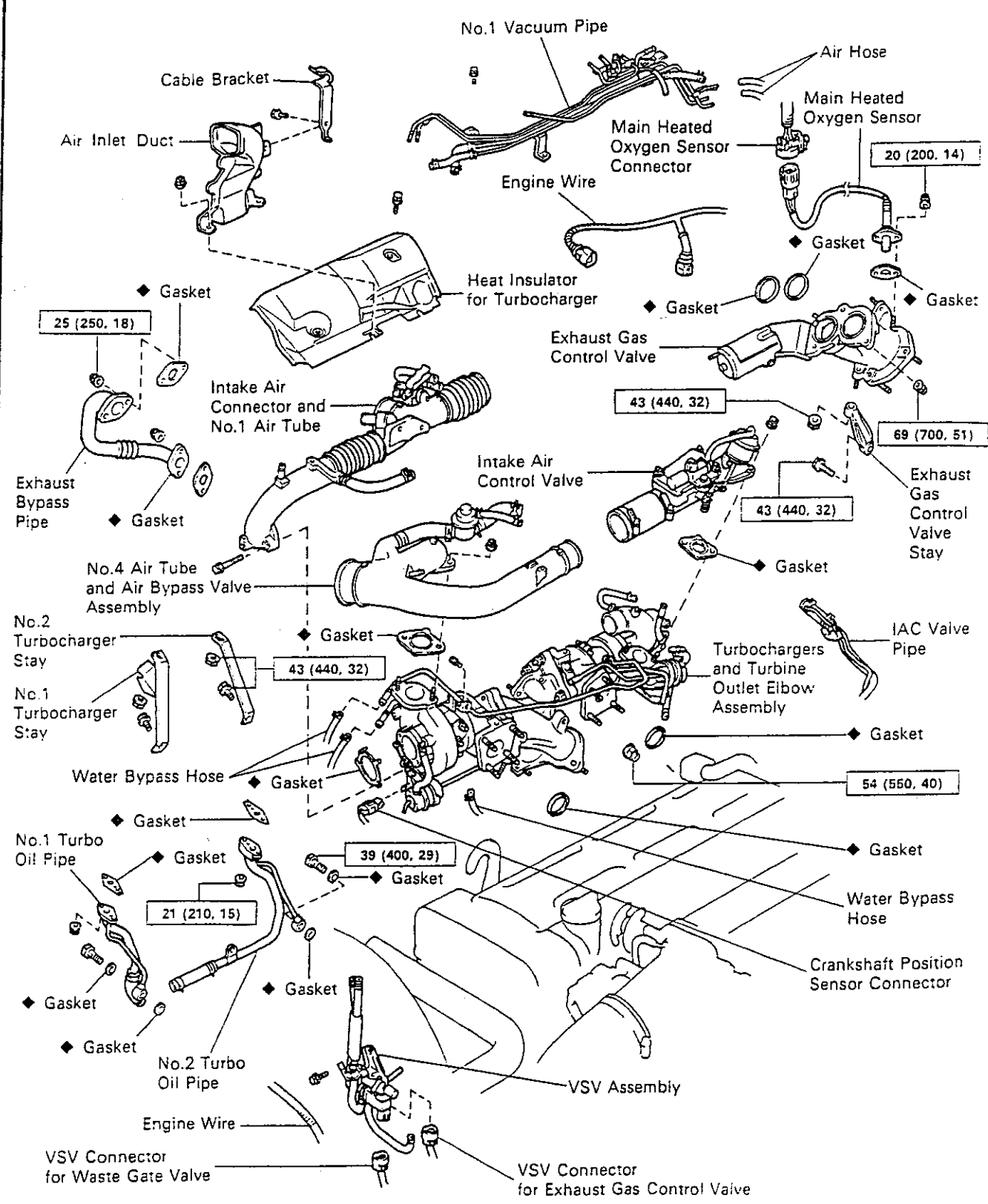

N·m (kgf·cm, ft·lbf) : Specified torque  
 ◆ Non-reusable part



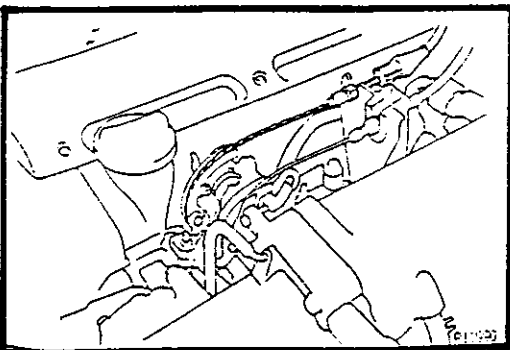
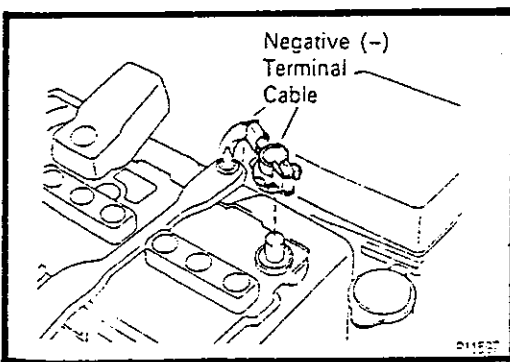
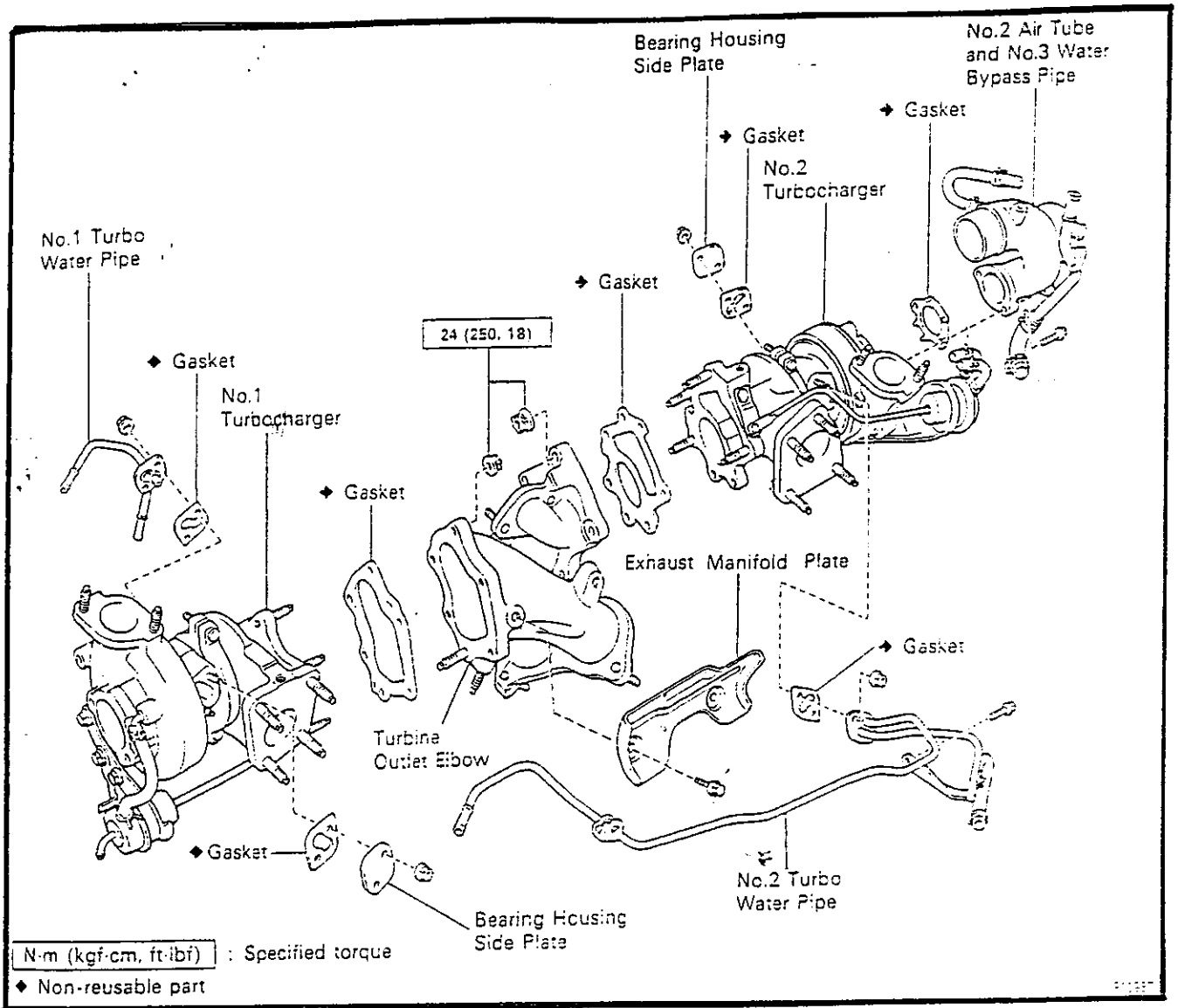

## TURBOCHARGER REMOVAL

(See Components for Removal and Installation)

1. DISCONNECT NEGATIVE TERMINAL CABLE FROM BATTERY  
CAUTION: Work must be started after 90 seconds from the time the ignition switch is turned to the "LOCK" position and the negative (-) terminal cable is disconnected from the battery.
2. DRAIN ENGINE COOLANT
3. REMOVE ENGINE UNDER COVER
4. DISCONNECT CRUISE CONTROL ACTUATOR CABLE FROM THROTTLE BODY

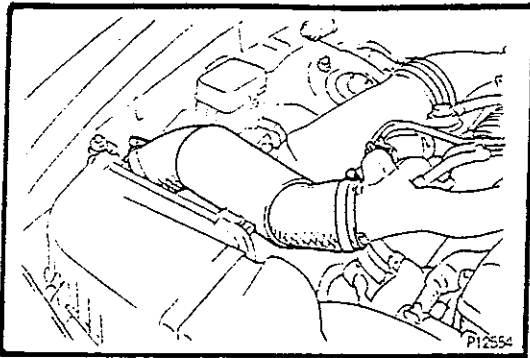

**5. REMOVE NO.1 AIR HOSE**

Loosen the 2 hose clamps, and remove the air hose.

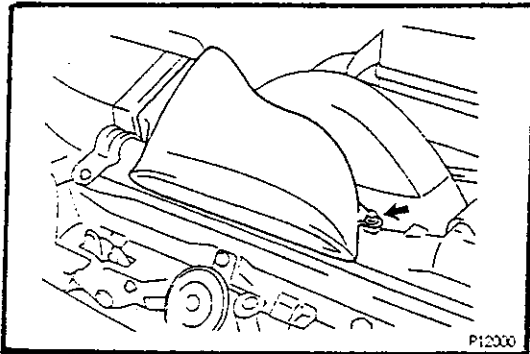

**6. REMOVE AIR CLEANER DUCT**

Remove the bolt and air cleaner duct.

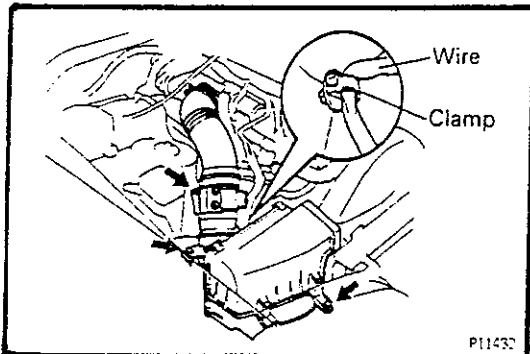

**7. REMOVE AIR CLEANER AND MAF METER ASSEMBLY**

- (a) Remove the 3 bolts.
- (b) Loosen the hose clamp, disconnect the air hose from the intake air connector.
- (c) Disconnect the MAF meter wire from the clamp on the air cleaner case.
- (d) Disconnect the MAF meter connector, and remove the air cleaner and MAF meter assembly.

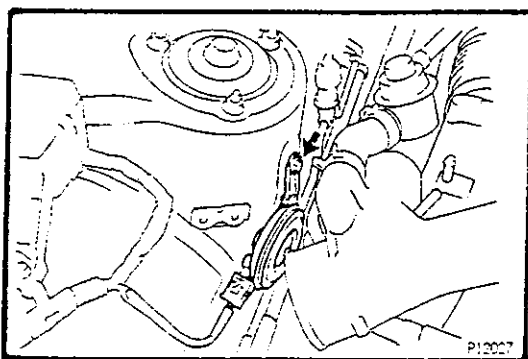

**8. DISCONNECT THEFT DETERRENT HORN FROM BODY**

Remove the bolt, and disconnect the horn from the body.

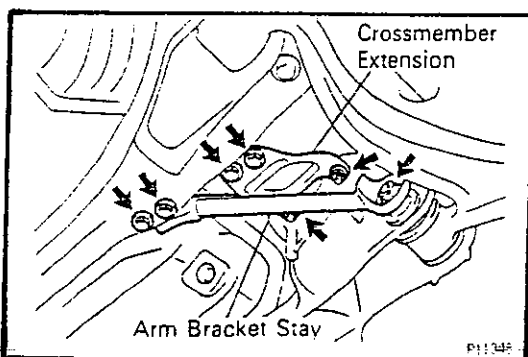

**9. REMOVE FRONT LOWER ARM BRACKET STAY**

Remove the 2 bolts, nut, plate washer and arm bracket stay.

**10. REMOVE UPPER FRONT CROSSMEMBER EXTENSION**

Remove the 2 bolts, 2 nuts and crossmember extension.

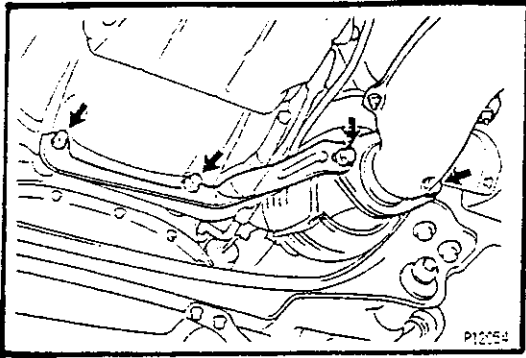

**11. REMOVE NO.2 FRONT EXHAUST PIPE**

- (a) Remove the 2 bolts and nuts holding the front exhaust pipe to the No.2 front exhaust pipe.
- (b) Remove the 2 bolts and pipe support bracket.
- (c) Disconnect the front exhaust pipe from the No.2 exhaust pipe. Remove the gasket.

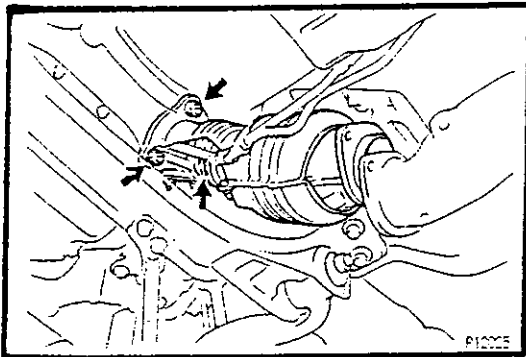

- (d) Remove the 3 nuts, No. 2 front exhaust pipe and gasket.

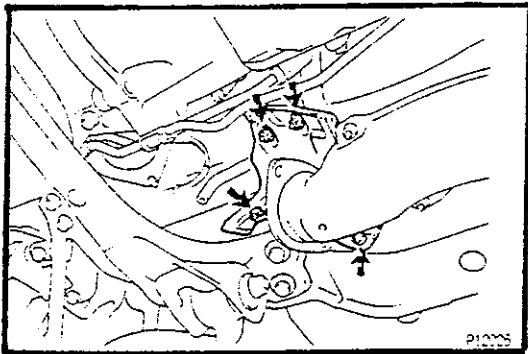

**12. REMOVE HEAT INSULATOR FOR NO.2 FRONT EXHAUST PIPE**

Remove the 2 bolts, 2 nuts and heat insulator.

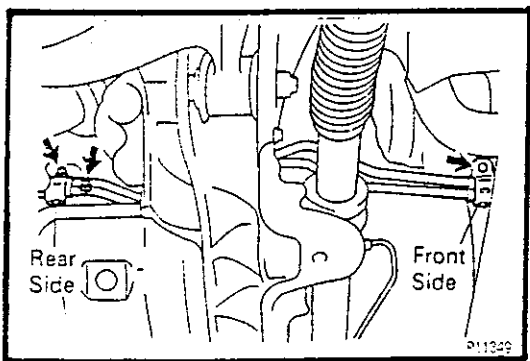

**13. DISCONNECT AT OIL COOLER TUBES FROM ENGINE**

- (a) Remove the bolt and tube clamp, and disconnect the oil cooler tubes from the bracket (front side) on the generator.
- (b) Remove the bolt and tube clamp, and disconnect the oil cooler tubes from the bracket (rear side) on the cylinder block.
- (c) Remove the bolt and tube bracket (rear side) from the cylinder block.

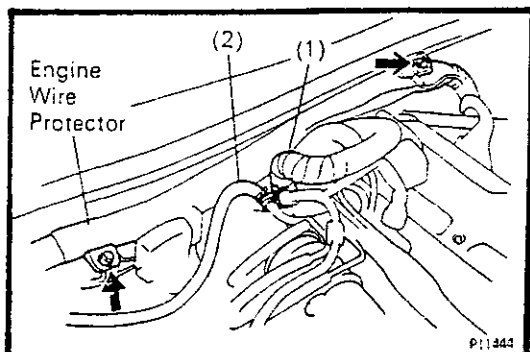

**14. DISCONNECT ENGINE WIRE PROTECTOR FROM BODY**

Remove the 2 bolts, and disconnect the wire protector from the body.

**15. DISCONNECT HOSES**

Disconnect the following hoses:

- (1) Heater hose from No.3 water bypass pipe
- (2) EVAP hose from No.1 vacuum pipe

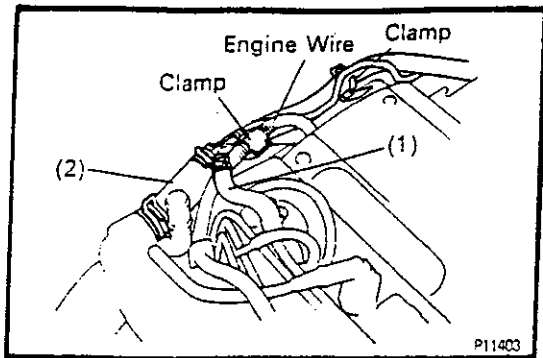

### 16. DISCONNECT IAC VALVE PIPE FROM NO.2 AIR TUBE

- (a) Disconnect the engine wire from the clamp.
- (b) Disconnect the following hoses:
  - (1) Air hose (from No.1 vacuum pipe) from IAC valve pipe
  - (2) Air hose from No.2 air tube
- (c) Disconnect the IAC valve pipe from the clamp.

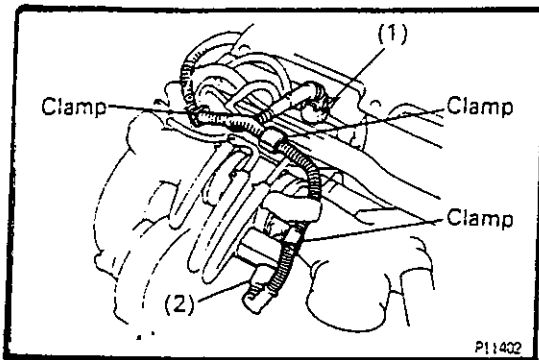

### 17. DISCONNECT NO.1 VACUUM PIPE FROM AIR TUBES

- (a) Disconnect the following connectors:
  - (1) VSV connector for intake air control valve
  - (2) VSV connector for exhaust bypass valve
- (b) Disconnect the engine wire from the 3 clamps.

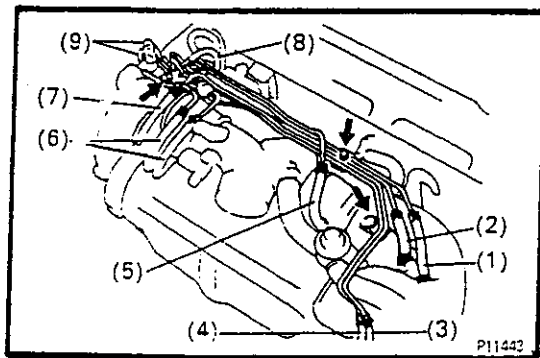

- (c) Disconnect the following hoses:
  - (1) Air hose from No.4 air tube
  - (2) Air hose from No.1 air tube
  - (3) Air hose (from VSV for waste gate valve) from vacuum pipe
  - (4) Air hose (from VSV for exhaust gas control valve) from vacuum pipe
  - (5) Vacuum hose (from air bypass valve) from No.1 air tube
  - (6) 2 air hoses (from VSV for exhaust bypass valve) from vacuum pipe
  - (7) Air hose (from No.2 air tube) from vacuum pipe
  - (8) Air hose from VSV for intake air control valve
  - (9) 2 air hoses (from pressure tank) from vacuum pipe
- (d) Remove the 3 bolts, and disconnect the vacuum pipe from the air tubes.

### 18. REMOVE VSV ASSEMBLY

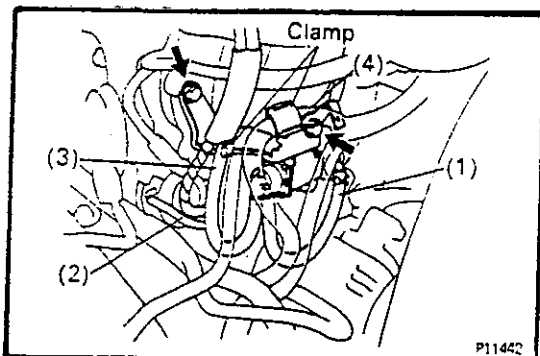

- (a) Disconnect the following hoses:
  - (1) Air hose from actuator for waste gate valve
  - (2) Air hose from actuator for exhaust gas control valve
  - (3) Air hose from hose clamp
  - (4) Engine wire from wire clamp
- (b) Remove the 2 bolts.
- (c) Disconnect the 2 VSV connectors, and remove the VSV assembly.

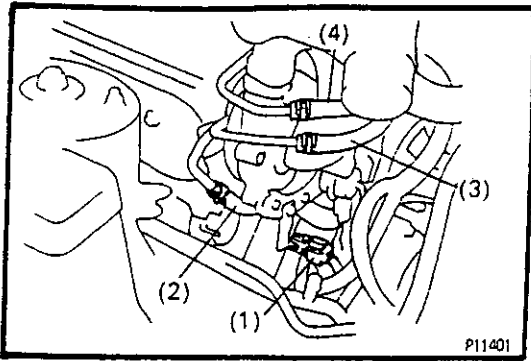

## 19. REMOVE AIR TUBES AND INTAKE AIR CONNECTOR

- (a) Disconnect the following connector and hoses:
- (1) Crankshaft position sensor connector from clamp
  - (2) Water bypass hose (from water pump) from No.1 turbo water pipe
  - (3) Water bypass hose (from water outlet) from No.1 turbo water pipe
  - (4) Water bypass hose (from water outlet) from No.2 turbo water pipe
- (b) Remove the bolt, and disconnect the No.2 turbo water pipe from the No.4 air tube.

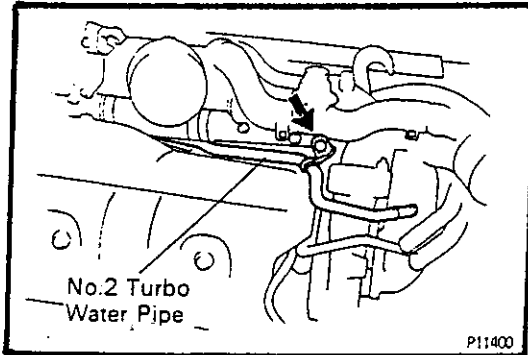

- (c) Remove the 2 bolts, and disconnect the No.1 air tube from the No.1 turbocharger. Remove the gasket.

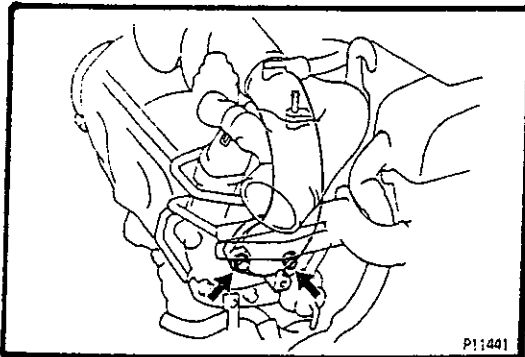

- (d) Remove the 2 bolts holding the No.4 air tube to the No.1 turbocharger. Remove the gasket.

- (e) Disconnect the following hoses, and remove the No.4 air tube and air bypass valve assembly.

- (1) Air hose from No.4 air tube
- (2) Air hose from intake air connector

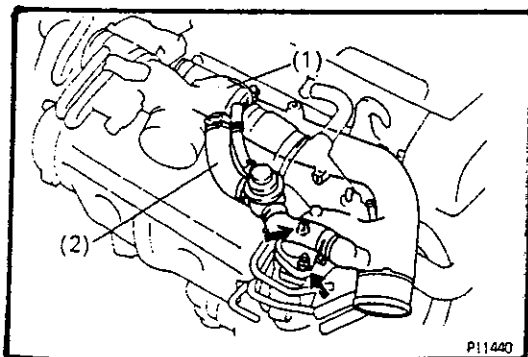

- (f) Remove the 2 nuts, intake air control valve and gasket.

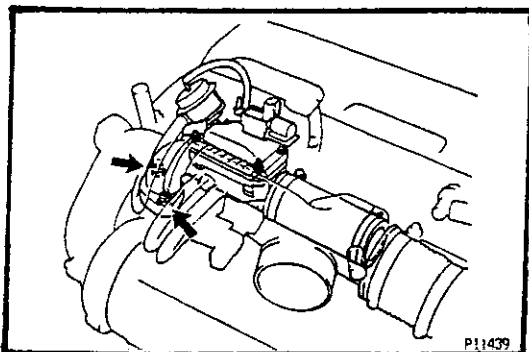

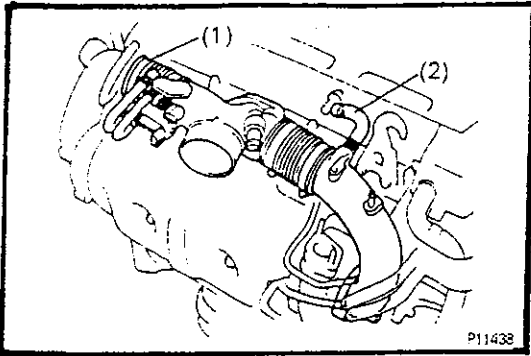

- (g) Disconnect the following hoses, and remove the intake air connector and No.1 air tube assembly.
- (1) Air hose from No.2 air tube
  - (2) PCV hose from No.2 cylinder head cover

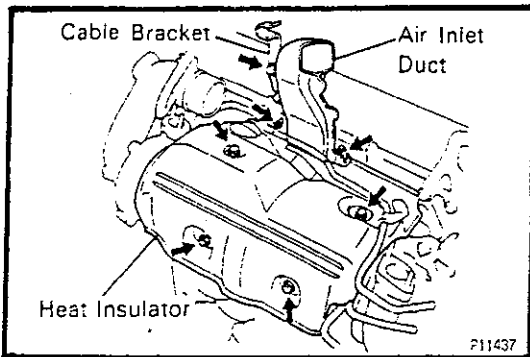

**20. REMOVE AIR INLET DUCT**

Remove the bolt, 2 nuts, cable bracket and air inlet duct.

**21. REMOVE HEAT INSULATOR FOR TURBOCHARGER**

Remove the 4 bolts and heat insulator.

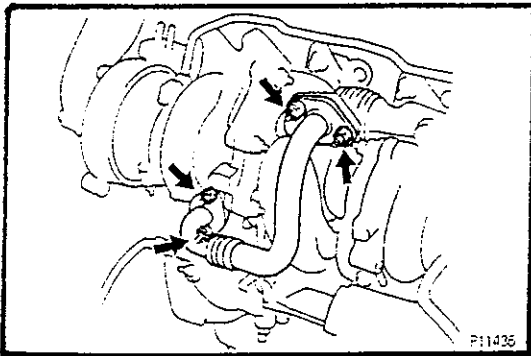

**22. REMOVE EXHAUST BYPASS PIPE**

Remove the 4 nuts, bypass pipe and 2 gaskets.

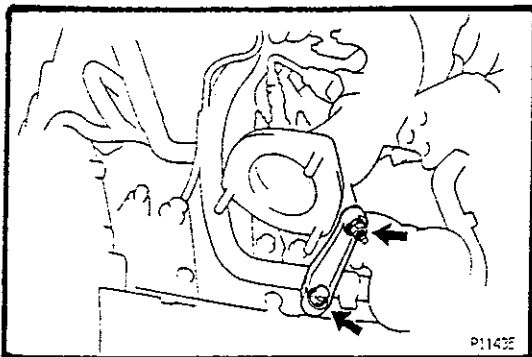

**23. REMOVE EXHAUST GAS CONTROL VALVE STAY**

Remove the bolt, nut and valve stay.

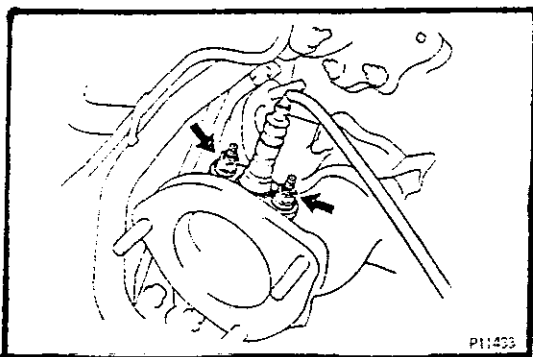

**24. REMOVE MAIN HEATED OXYGEN SENSOR**

- (a) Disconnect the oxygen sensor connector.
- (b) Remove the 2 nuts, oxygen sensor and gasket.

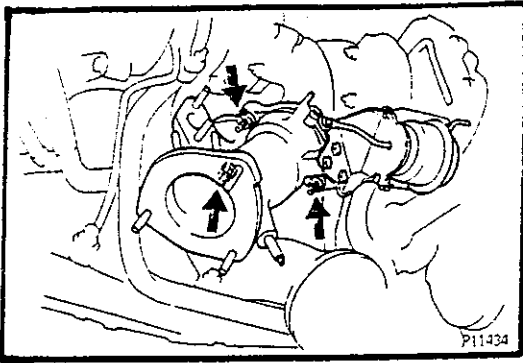

## 25. REMOVE EXHAUST GAS CONTROL VALVE

Remove the 3 nuts, control valve and 2 gaskets.  
**NOTICE:** The control valve is ceramic. Do not drop or knock the control valve.

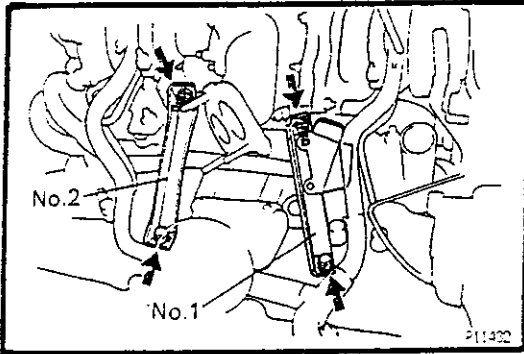

## 26. REMOVE NO.1 TURBOCHARGER STAY

Remove the bolt, nut and turbocharger stay.

## 27. REMOVE NO.2 TURBOCHARGER STAY

Remove the bolt, nut and turbocharger stay.

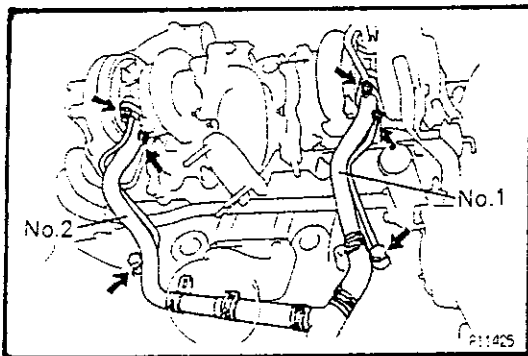

## 28. REMOVE NO.1 TURBO OIL PIPE

- (a) Remove the union bolt holding the turbo oil pipe to the cylinder block. Remove the 2 gaskets.
- (b) Remove the 2 nuts, and disconnect the turbo oil pipe from turbocharger. Remove the gasket.
- (c) Disconnect the turbo oil hose from the turbo oil outlet on the No.1 oil pan, and remove the turbo oil pipe.

## 29. REMOVE NO.2 TURBO OIL PIPE

- (a) Remove the union bolt holding the turbo oil pipe to the cylinder block. Remove the 2 gaskets.
- (b) Remove the 2 nuts, and disconnect the turbo oil pipe from turbocharger. Remove the gasket.
- (c) Disconnect the turbo oil hose from the turbo oil outlet on the No.1 oil pan, and remove the turbo oil pipe.

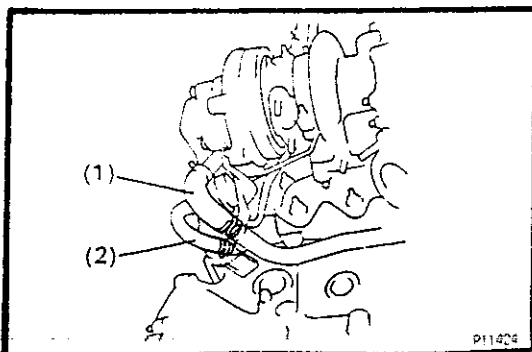

## 30. REMOVE TURBOCHARGERS AND TURBINE OUTLET ELBOW ASSEMBLY

- (a) Disconnect the following hoses:
  - (1) Heater hose (from No.3 water bypass pipe) from No.2 water bypass pipe
  - (2) Water bypass hose (from No.2 turbo water pipe) from No.2 water bypass pipe

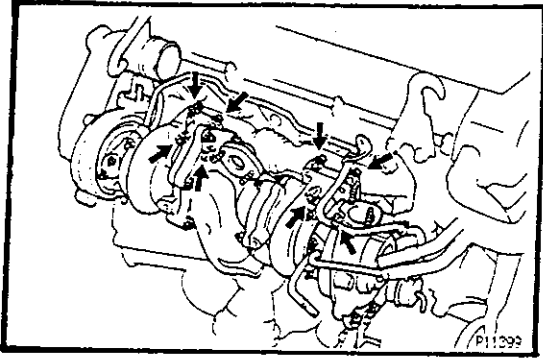

- (b) Remove the 8 nuts holding the turbochargers to the exhaust manifold.
- (c) Remove the 2 turbochargers and turbine outlet elbow assembly.
- (d) Remove the 2 gaskets.



### 3. GReddy Turbo Kit Installation

#### 3-1 Plugging the Water Lines.

(1) Reroute and plug the front turbo water hoses as shown in "A" and "B"  
Use: #48 at "B" and a (stock) hose Clamp at "A"

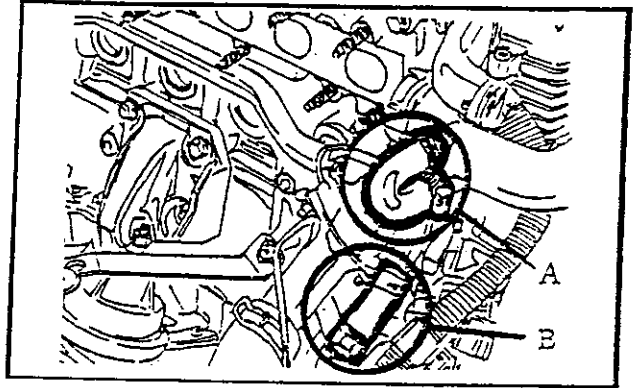

(2) Cap off the rear turbo water hose at point "C" with the provided plug union.  
Use: #48 at "C" and thermo cloth #50 at "C" and "D"

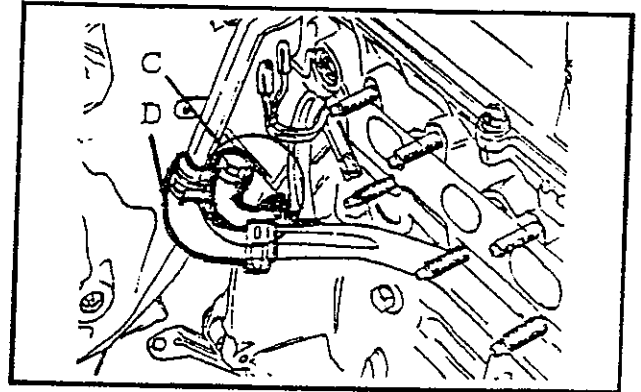

#### 3-2 Oil Pressure Line Installation

(1) At the rear end of the engine block, cap Off the oil pressure hole with the provided copper washer and plug bolt. (This hole was used for the old oil feed line for the rear turbo).

Use: #16,19

Use teflon tape or sealant on the plug bolt to get a proper seal.

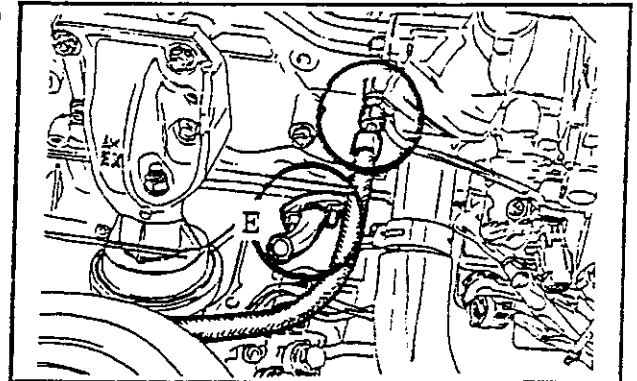

(2) At the front oil pressure outlet  
Install the provided oil pressure line using the adapter union, straight union and copper washer.

Use: #12,14,15,18,19

### 3-3 Oil Return Installation

(1) Bolt the oil return pipe onto the block with the gasket as shown.

Use: #21,46

### 3-4 Exhaust Manifold Installation

(1) Install the exhaust manifold stud bolts onto the cylinder head.

Use: #57

(2) Install the new exhaust manifold. Torque the nuts to factory specifications.

Use: #3,42

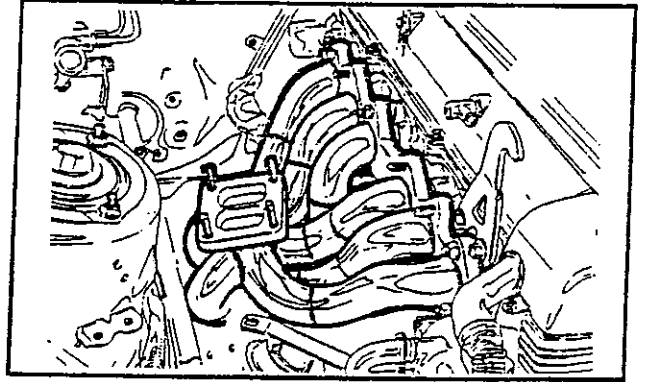

### 3-5 Turbocharger Installation

(1) Install the stud bolts onto the turbo inlet flange on the exhaust manifold.

Use: #57

(2) Install the oil return pipe onto the turbocharger with the provided gasket.

Use: #1,20,46,56

(3) Install the turbocharger onto the exhaust manifold.

Use: #1,43

(4) Cut the 19Ø rubber hose to 150mm and connect the oil return line between the turbo to the block.

Use: 29,32,50

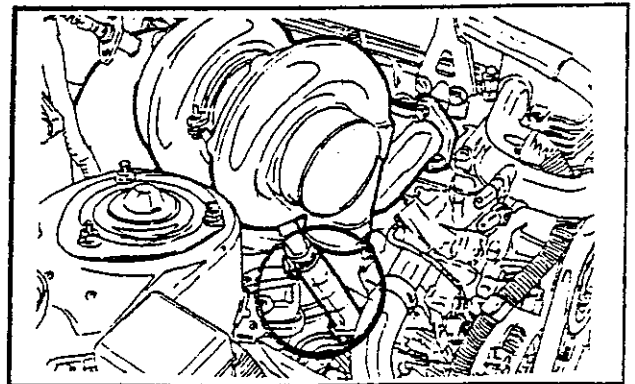

(5) Connect the oil pressure line installed in step 3-2 to the turbo-charger using the banjo fitting.  
Use: #13,17

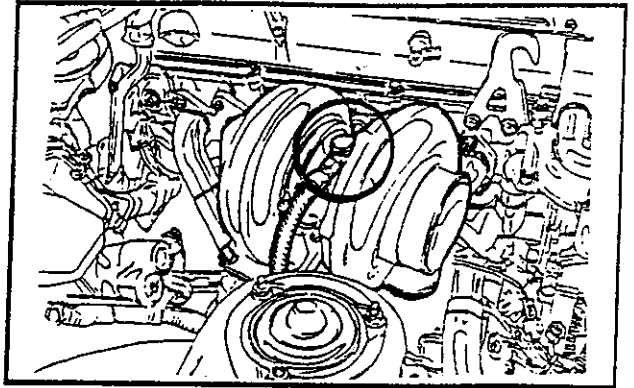

### 3-6 Wastegate Installation

(1) Bolt the wastegate dump pipe onto the Type-R wastegate.  
Next install the two straight unions onto the wastegate as shown.  
Use: #2,4,39

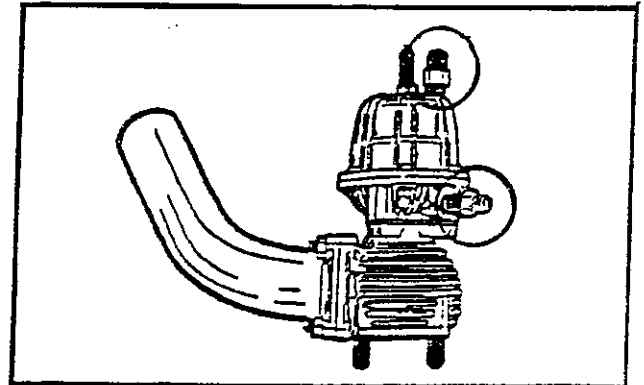

(2) Install the wastegate onto the exhaust manifold as shown.  
(view is from under the car)  
Use: #2



### 3-7 Down Pipe Installation

(1) Install the down pipe onto the turbocharger using the gasket provided.  
Use: #5,44,56

(2) Connect the down pipe to the catalytic converter using the provided exhaust gasket.  
Use: #45,58

(3) Install the O<sup>2</sup> sensor onto the down pipe with the enclosed gasket. Also it is important to wrap the O<sup>2</sup> wire with the thermo cloth and to wire tie the wire away from the turbocharger.  
Use: #47,55,50

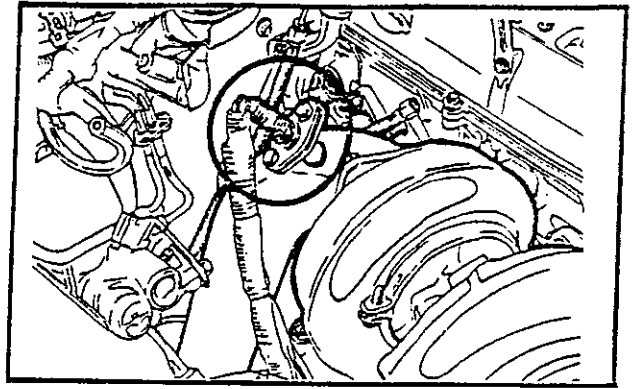

### 3-8 Installation of Charge Pipes

(1) Install the charge pipes C-1 and C-2 in-between the turbocharger and intercooler using the appropriate silicone hoses. Wrap the silicone hose at the turbo outlet with thermo wrap.  
Use: #6,7,22,24,25,33,34,35,50

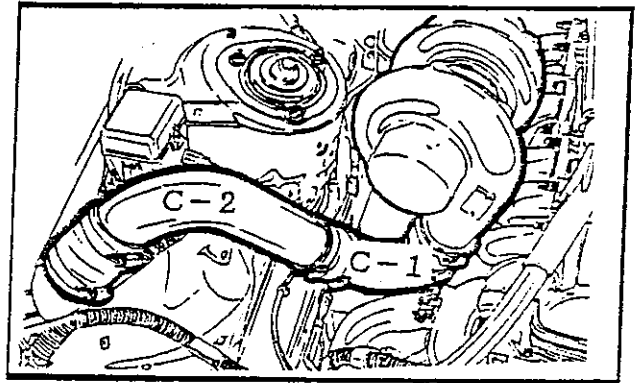

### 3-9 Air Filter and Suction Pipe Installation *USA Version Supra*

(1) Install the Airinx Adapter Kit (sold separately) to the Airinx. Next attach the factory air flow meter to the Airinx adapter.  
Use: #10 & part #525901

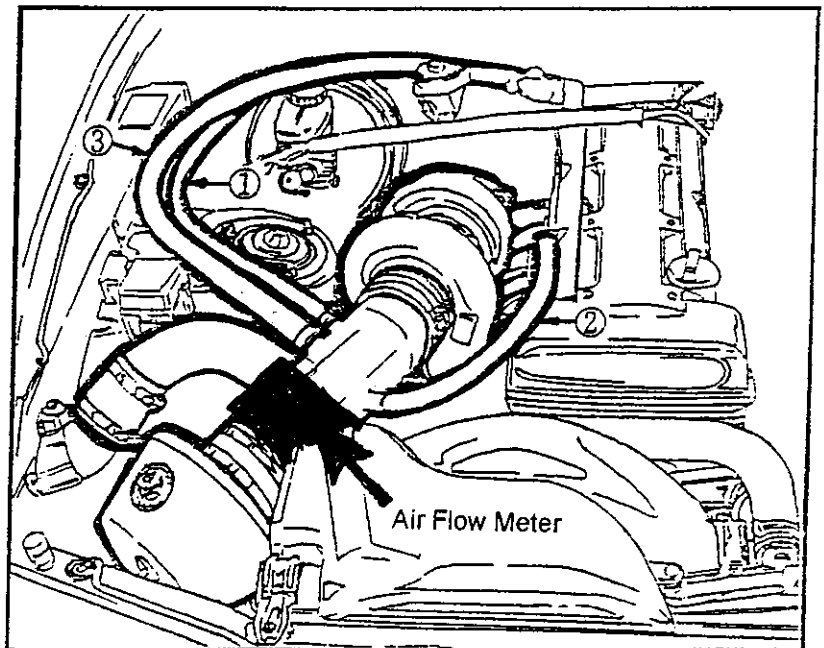

(2) Modify (cut) the supplied suction pipe to allow the Airinx assembly to fit in the engine compartment. Then install the complete air intake assembly onto the turbocharger inlet.

Use: #23,36

(3) Suction pipe hose installation:

- (a) 8Ø hose to the canister line.
- (b) 12Ø hose to the valve cover breather.
- (c) 19Ø hose to the ISCV pipe.

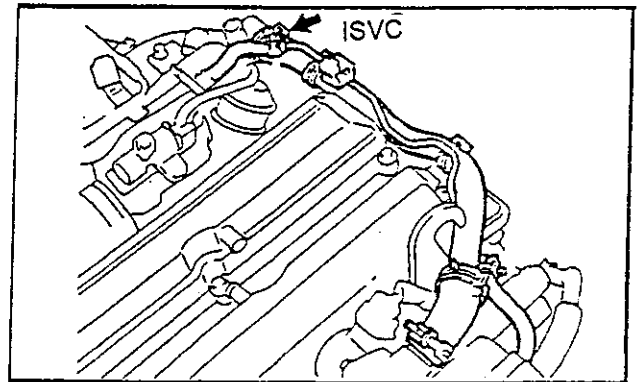

### 3-10 Heat Shield Installation

(1) Install the heat shield bracket onto the heat shield.

Use: #9,49,54

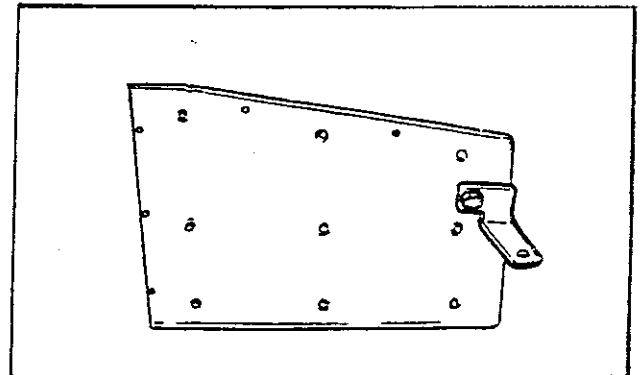

(2) Attach the heat shield as shown.

Use: #53

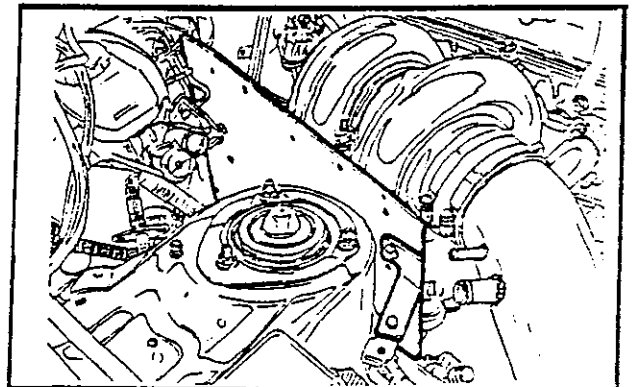

(3) Bolt down the air filter assy. using one of the factory air box holes.

Use: # 51

### 3-12 Hose Routing for the Wastegate

- (1) Connect the side port of the wastegate to the surge tank.
- (2) If you are using a boost controller connect the top port of the wastegate to the "IN" or "B" port of your boost controller (Read you boost controller instruction manual).

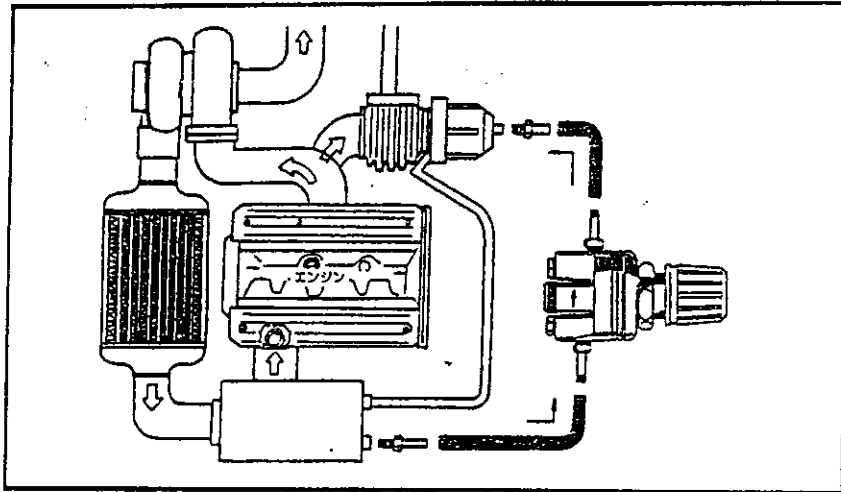

### 3-12 Throttle Cable

- (1) Cover the portion of the throttle cable that runs over the turbocharger and exhaust manifold with the supplied thermo cloth.  
Use: # 50

### 3-13 Checking for Leaks.

- (1) Refill coolant levels
- (2) Reconnect the negative terminal of the battery
- (3) Crank the engine, without starting it to build proper oil pressure before starting the engine.
- (4) Start the engine and check for oil, water, and air leaks.

**This completes the installation.**